

(12) INTERNATIONAL APPLICATION PUBLISHED UNDER THE PATENT COOPERATION TREATY (PCT)

(19) World Intellectual Property Organization  
International Bureau



(43) International Publication Date  
24 April 2003 (24.04.2003)

PCT

(10) International Publication Number  
WO 03/033612 A1

- (51) International Patent Classification<sup>7</sup>: C09J 123/10
- (21) International Application Number: PCT/US02/26297
- (22) International Filing Date: 16 August 2002 (16.08.2002)
- (25) Filing Language: English
- (26) Publication Language: English
- (30) Priority Data:  
09/982,641 18 October 2001 (18.10.2001) US
- (71) Applicant: **BOSTIK FINDLEY, INC.** [US/US]; 11320 Watertown Plank Road, Wauwatosa, WI 53226 (US).
- (72) Inventors: **WANG, Baoyu**; W226 N2818 Foxwood Lane, Waukesha, WI 53186 (US). **ZHANG, Chongyao**; 4045 North Prospect Avenue, Shorewood, WI 53211 (US).
- (74) Agents: **WOZNY, Thomas, M.** et al.; Andrus, Sceales, Starke & Sawall, LLP, Suite 1100, 100 East Wisconsin Avenue, Milwaukee, WI 53202 (US).
- (81) Designated States (*national*): AE, AG, AL, AM, AT, AU, AZ, BA, BB, BG, BR, BY, BZ, CA, CH, CN, CO, CR, CU, CZ, DE, DK, DM, DZ, EC, EE, ES, FI, GB, GD, GE, GH, GM, HR, HU, ID, IL, IN, IS, JP, KE, KG, KP, KR, KZ, LC, LK, LR, LS, LT, LU, LV, MA, MD, MG, MK, MN, MW, MX, MZ, NO, NZ, OM, PH, PL, PT, RO, RU, SD, SE, SG, SI, SK, SL, TJ, TM, TN, TR, TT, TZ, UA, UG, UZ, VN, YU, ZA, ZM, ZW.
- (84) Designated States (*regional*): ARIPO patent (GH, GM, KE, LS, MW, MZ, SD, SL, SZ, TZ, UG, ZM, ZW), Eurasian patent (AM, AZ, BY, KG, KZ, MD, RU, TJ, TM), European patent (AT, BE, BG, CH, CY, CZ, DE, DK, EE, ES, FI, FR, GB, GR, IE, IT, LU, MC, NL, PT, SE, SK, TR), OAPI patent (BF, BJ, CF, CG, CI, CM, GA, GN, GQ, GW, ML, MR, NE, SN, TD, TG).

**Published:**  
— with international search report

*For two-letter codes and other abbreviations, refer to the "Guidance Notes on Codes and Abbreviations" appearing at the beginning of each regular issue of the PCT Gazette.*



WO 03/033612 A1

(54) Title: HOT MELT ADHESIVE COMPOSITION BASED ON A BLEND OF AMORPHOUS POLY- $\beta$ (A)-OLEFIN AND SYNDIOTACTIC POLYPROPYLENE

(57) Abstract: A hot melt adhesive composition based on a polymer blend of syndiotactic polypropylene (SPP) and atactic poly- $\alpha$ -olefin (APAO). The composition contains about 15%-80% by weight of the SPP/APAO blend, about 15%-65% by weight of a compatible tackifier, about 0%-35% by weight of a plasticizer, about 0%-3% by weight of a stabilizer, and optionally, about 0%-30% by weight of a wax. The adhesive composition may be used in a number of applications such as, for example, in disposable non-woven hygienic articles, paper converting, flexible packaging, wood working, carton and case sealing, labeling and other assembly applications.

## HOT MELT ADHESIVE COMPOSITION BASED ON A BLEND OF AMORPHOUS POLY- $\alpha$ -OLEFIN AND SYNDIOTACTIC POLYPROPYLENE

### FIELD OF THE INVENTION

5           This invention relates to novel hot melt adhesive compositions based on polymer blends which consists of stereospecific, predominately crystalline syndiotactic polypropylene homo- and co-polymers (SPP) and amorphous atactic poly- $\alpha$ -olefins (APAO). More particularly, this invention relates to adhesive compositions that find utility in case/carton sealing and in manufacturing  
10 nonwoven disposable articles such as diapers and feminine hygiene products. The adhesive compositions are particularly useful as an elastic attachment and construction adhesive in assembly of disposable nonwoven articles.

### BACKGROUND OF THE INVENTION

15           Hot melt adhesives typically exist as solid masses at ambient temperature and can be converted to a flowable liquid by the application of heat. These adhesives are particularly useful in manufacturing a variety of disposable goods where bonding of various substrates is often necessary. Specific applications include disposable diapers, hospital pads, feminine sanitary napkins, pantyshields,  
20 surgical drapes and adult incontinent briefs, collectively known as disposable nonwoven products. Other diversified applications have involved paper products, packaging materials, tapes and labels. In most of these applications, the hot melt adhesive is heated to its molten state and then applied to a substrate. A second substrate is then immediately brought into contact with and compressed against the  
25 first. The adhesive solidifies on cooling to form a strong bond. The major advantage of hot melt adhesives is the absence of a liquid carrier, as would be the case of water or solvent based adhesives, thereby eliminating the costly process associated with solvent removal.

30           For many applications, hot melt adhesives are often extruded directly onto a substrate in the form of a thin film by using piston or gear pump equipment. In this

case, the substrate is brought into intimate contact with a hot die under pressure. The temperature of the die must be maintained well above the melting point of the adhesive, which is typically between 150 and 200 °C. For some applications, particularly for manufacturing nonwoven articles, bonding of delicate and heat sensitive substrates, such as thin gauge polyethylene films, is often involved. Direct contact between the film and the die, in these cases, must be avoided to prevent the film from burning or distorting. Several application methods have been developed through which a hot melt adhesive can be spray coated with the aid of compressed air onto a substrate from a distance. These non-contact coating techniques include spiral spray and various forms of melt-blown methods. Direct contact between the coating head and the substrate is thus eliminated. All the coating techniques herein described above are well know to those skilled in the art and commercial equipment is readily available.

The spray coating techniques, however, pose stringent requirements on hot melt adhesives. The viscosity of the adhesives must be sufficiently low, usually in the range of 2,000 to 30,000 cP, preferably in the range of 2,000 to 15,000 cP, at the application temperature. Many other physical factors, especially the rheological properties of the adhesive, come into play in determining the sprayability of a hot melt. The majority of commercial hot melt products do not lend themselves to spray applications. There are no accepted theoretical models or guidelines to predict sprayability and it must be determined empirically with application equipment.

In accordance with the present invention, it has been found that a mixture comprising a polymer blend of SPP and APAO, a tackifying resin, a plasticizer and, optionally, a synthetic polyolefin wax or petroleum wax provides a sprayable hot melt adhesive composition. The composition has novel combinations of properties including toughness, low or no shrinkage, high cohesive strength, low viscosity, excellent heat stability and good adhesion to a variety of substrates. The composition of the present invention is particularly useful in assembly of

disposable nonwoven articles for bonding of polyethylene and polypropylene films, nonwoven fabrics and elastic strands to each other or to themselves.

One of the components in the polymer blend is the syndiotactic polypropylene (SPP) polymers. The SPP polymers useful in this invention are essentially high molecular weight stereospecific propylene homopolymers or copolymers of propylene with other  $\alpha$ -olefin monomers such as ethylene, butene-1 or hexene-1. The syndiotactic polymers should not be confused with the conventional crystalline polypropylenes and essentially amorphous atactic poly- $\alpha$ -olefins (APAO). These polymers differ from each other in both structures and properties. It is well know to those skilled in the art that the conventional crystalline polypropylenes have an isotactic molecular chain configuration. The isotactic configuration can be described as having the methyl groups attached to the tertiary carbon atoms of successive monomeric units on the same side of a hypothetical plane drawn through the main polymer chain. This type of stereochemistry structure can be illustrated graphically by using the Fisher projection formula as the follow:



Due to its high degree of chain regularity, the conventional isotactic polypropylenes (IPP) are highly crystalline with crystallinity typically greater than 50% and a heat of fusion greater than 70J/g. They are usually stiff materials having high density and high melting point. Due to the lack of flexibility, an IPP polymer can only be used as a modifier in small amounts, typically around 2% to 5% by weight, in hot melt adhesive formulations. A typical conventional IPP usually has a melt flow rate, which is inversely related to the weight average molecular weight, in the range of 0.5 to 200 g/10 min as measured in accordance with ASTM D-1238 test method.

Another component of the polymer blend comprises an APAO polymer. APAO polymers are a family of essentially amorphous low molecular weight homopolymers of propylene or copolymers of propylene with ethylene or butene or

hexene. In contrast to the regular structures in IPP or SPP, APAOs have atactic molecular chains with the methyl groups on the successive monomeric units sterically randomly distributed on both sides of the hypothetical plane through the polymer chain. The stereo configuration of the atactic APAO molecular chain can be illustrated graphically by using the following Fisher projection formula:

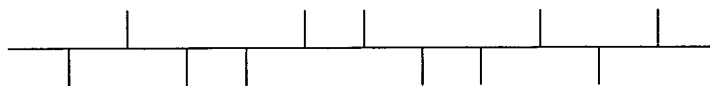

The stereo chain structure of SPP is uniquely different from that of IPP and from that of APAO. In contrast to the isotactic chain configuration of IPP and the atactic chain configuration of APAO, the stereochemistry of SPP can be described as having the tertiary methyl groups of successive monomer units along the chain alternatively disposed on each side of the hypothetical plane. The stereo configuration of SPP can be depicted below:



The stereo configuration of polypropylene can also be characterized quantitatively through C-13 NMR. In NMR nomenclature, a "meso" dyad of successive methyl groups on the same side of the plane, as in the case of IPP, is represented by the letter m. A "racemic" dyad of successive methyl groups on the opposite sides of the plane, as in the case of SPP, is represented by the letter r. The percentage of m or r defines the degree of polymer tacticity with the sum of m and r equal to 100%. Thus, a perfect isotactic polypropylene will have 100% m dyad, whereas a perfect syndiotactic polypropylene will have 100% r dyad. This unique stereochemical structure of SPP results in an unusual and desirable combination of physical and mechanical properties such as low density, low melting point, flexibility and toughness.

The syndiotactic polymers used in the present invention preferably have an r value equal to or greater than 70%. The polymers having an r value greater than

80% are more preferred and those having an r value greater than 85% is most preferred. It should be pointed out that the r values of conventional IPPs, in comparison, are generally in a few percent range.

In addition to the difference in stereochemistry, SPPs are also readily  
5 distinguishable from IPPs and APAOs by their unique physical properties. Typical SPPs will have a melting point between 130 to 160 °C, whereas crystalline IPPs typically have a melting point about 176 °C. APAOs, on the other hand, are usually predominately amorphous without a well-defined melting point although some grades of commercial products may exhibit very low degree of crystallinity.  
10 Another profound difference between SPP and IPP and APAO lies in their densities. The density of SPP is typically between 0.86 to 0.90 g/cm<sup>3</sup>, which is in between those of IPP and APAO. IPPs have the highest density ranging from 0.90 to 0.95 g/cm<sup>3</sup> and APAOs, the lowest ranging from 0.85 to 0.87 g/cm<sup>3</sup>.

Due to their high melting point, high degree of crystallinity and the lack of  
15 desirable physical and mechanical attributes such as flexibility and toughness, the conventional IPPs have not been used alone as the polymer base for hot melt adhesive applications. A hot melt adhesive based on IPP would be too brittle to offer acceptable bond strength and yet would require high application temperature that goes well beyond the melting point of the polymer.

20 Hot melt adhesives containing APAOs, APAO/polyethylene (PE) blends, APAO/polybutene (PB) blends, or APAO/IPP blends are known in the art. These adhesives typically consist of an APAO, or an APAO blend herein mentioned above, and a hydrocarbon type of tackifier. It is well know that adhesives based on APAOs generally have poor cohesive strength, poor heat resistance, low elevated  
25 temperature bond strength and low shear values. APAOs have not found much use in disposable nonwovens applications where a combination of high bond strength at very low coating weight and easy processibility by spray techniques is required. The APAO based adhesives usually lack such capabilities. Although various attempts were made to address these problems by blending APAO with PE,

PB and the conventional IPP, very often such modifications not only failed to rectify the problems, but also led to adverse side effects.

For example, Trotter et al, in U.S. Patent No. 4,022,728, describes a hot melt pressure sensitive composition comprising a mixture of APAOs, a low molecular weight substantially amorphous elastomer, a liquid tackifier and a conventional crystalline polypropylene (IPP) in the amount of up to 2% by weight. It is claimed that the composition provides good adhesive properties at low temperatures.

Meyer et al, in U.S. Patent 4,120,916, discloses hot melt adhesive compositions comprising a blend of low molecular weight polyethylene, low molecular weight conventional propylene containing polymer and APAO. These adhesive compositions are said to offer short open time and to be useful for bonding of paraffin modified corrugated board.

Lakshmanan et al, in U.S. Patent No. 4,761,450, discloses a polymer blend useful as hot melt adhesive comprising a low density ethylene polymer, a copolymer of butene-1 with ethylene or propylene, a hydrocarbon tackifier and a low molecular weight polymer consisting of a low molecular weight liquid polybutene, an amorphous polypropylene and mixtures thereof.

Lakshmanan et al, in U.S. Patent No. 5,478,891, also discloses blend compositions containing (a) a high molecular weight copolymer of ethylene with an  $\alpha$ -olefin having at least 4 carbons and (b) an amorphous polypropylene or amorphous polyolefin. The components of the blends are described as having molecular weight range between 300 to 6000. The polymer blends are claimed to be useful for hot melt adhesives, coatings, sealants, asphalt modifiers and plastic additives.

Ryan discloses in U.S. Patent No. 5,747,573 an APAO based hot melt adhesive composition useful for bonding plastics and metallized foil containers. The adhesive composition contains a blend of APAO, a solid benzoate plasticizer and a hydrocarbon tackifier.

Sustic, in U.S. Patent No. 5,723,546, discloses a polymer blend consisting of a high molecular weight average, predominantly atactic flexible polyolefin polymer and a low molecular weight average APAO. The blend is said to be useful for hot melt adhesives.

5 Blending APAO with PE, PB or the conventional IPP leads to several drawbacks. The prior art adhesives containing APAO/PE or APAO/PB blends, such as, for example, those described herein above in U.S. Patents 4,120,916, 4,761,450, and 5,478,891, tend to have poor compatibility. These adhesives can undergo phase separation during application process at which the hot melt adhesives have to be  
10 kept in the molten state at high temperature for a prolonged period of time, sometimes for hours or even days. Charring, skinning and gelling can develop rather quickly in the phase separated hot melt adhesives, thereby causing the application equipment to block or plug-up. The incompatibility of such polymer blends also imparts brittleness, optical haziness, poor or no open time, and low  
15 bond strength. Although APAO and the conventional IPP blend based hot melt do not have the compatibility problems, they still suffer from all the other drawbacks herein described above. Moreover, due to high crystallinity and high melting point of the conventional IPP polymers, hot melt adhesives based on APAO/IPP blends tend to be hard and brittle unless the IPP polymer amount is kept at a very low  
20 level, such as, for example, at about or below 2% by weight as disclosed in the prior art U.S. Patent 4,022,728. As a result, these adhesives will have poor tensile strength, poor bond strength and poor impact resistance. Another detrimental effect of IPP is the increased coating temperature. The adhesive must be heated above the melting point of IPP (ranging from 180 to 200 °C) for it to reach a liquid state. The  
25 blend of high and low molecular weight atactic polyolefin approach described in U.S. Patent 5,723,546, although offering some improvement on tensile properties of APAO, has not been able to provide sufficient tensile strength and high temperature properties to overcome the deficiencies of sole APAO based hot melts.



In a prior U.S. Patent 5,317,070, Brant et al disclosed a hot melt adhesive based on tackified SPP having a polymer chain of at least 80% racemic dyads and having a melting point of about 100 to 180 °C. The adhesive is claimed to have good open times between the application of the adhesive and the formation of the joint. This type of tackified SPP usually lacks flexibility and toughness, and therefore, will also have poor bond strength and poor impact resistance. Furthermore, SPP exhibits an inherent shrinkage problem when it transforms from liquid to solid crystalline state. The shrinkage often causes stress concentration at adhesive/substrate interfaces, and consequently, catastrophic bond failure.

It therefore would be advantageous to provide a hot melt adhesive that will overcome the shortcomings of the prior art adhesives herein mentioned above. It is found in the present invention that a synergistic effect exists in an SPP/APAO blend hot melt composition. Due to this synergy, an SPP/APAO polymer blend possess a unique combination of properties which the prior art APAO and SPP based hot melt systems have failed to offer.

#### SUMMARY OF THE INVENTION

The present invention is directed to a hot melt adhesive composition based on a polymer blend of the SPP and APAO. The adhesive comprises, in addition to the SPP/APAO blend, a tackifying resin, an optional plasticizer and an optional wax as the primary ingredients. The composition of the present invention takes advantage of complimentary properties between SPP and APAO and has overcome the shortcomings of the prior art APAO blend adhesives and tackified SPPs. The composition of the present invention provides well balanced properties of tensile strength, toughness, flexibility and adhesion. It shows complete compatibility, excellent heat stability, adjustable open time, improved cohesive strength, low viscosity, low shrinkage upon solidification, low or no tack when set, and good processibility with conventional coating equipment. In particular, the present invention leads to an adhesive composition that is well suited for a variety of spray

coating application techniques, such as, for example, spiral spray, melt-blown, control coat, control wave and the like, whereas the prior art APAO and SPP based adhesives lack such broad processibility.

5 One of the prominent features of the hot melt adhesive composition of the present invention is its ability to provide a strong bond to a variety polar and nonpolar substrates at very low coating weight. The adhesive works well on both porous and film substrates. At the equal coating weight, the present adhesive will yield a much higher peel adhesion value than the prior art adhesives. The ability to yield high peel strength at low coating weight enables the end user to use less  
10 adhesive, which is obviously a great cost benefit.

One objective of the present invention is to provide an adhesive that has very low or no tack at ambient temperature. This feature is particularly advantageous for use on porous substrates where adhesive bleed-through and the subsequent blocking are of great concern. Blocking is especially disastrous in the  
15 manufacturing of roll-goods. The roll goods are usually intermittent products that will be converted to end products in a subsequent process. Roll blocking makes it difficult, and sometimes even impossible to unwind the roll in the subsequent converting process. The non-tacky characteristic of the present adhesive in combination with low coating weight capability will eliminate the blocking  
20 problem.

Another objective of the present invention is directed towards a sprayable hot melt adhesive for construction of disposable nonwoven articles for binding polyethylene, polypropylene films, nonwoven fabrics and the like to each other and to themselves. The adhesive provides excellent peel strength and bond durability in  
25 such application.

Another objective of the present invention is to provide a sprayable hot melt for elastic attachment application in manufacturing baby diapers, adult incontinent briefs and the like for binding elastic strands between a polyethylene film and a

nonwoven fabric, or between two nonwoven fabrics. This type of adhesive can be formulated to have dual functions for both elastic attachment and construction.

Another objective of the present invention is to provide a hot melt adhesive for carton and case sealing to provide a strong bond at sub-ambient temperatures.

5 Due to its toughness and flexibility, an SPP/APAO based hot melt is advantageous for low temperature applications. The adhesive of the present invention would offer fiber tear bond at the ambient temperature.

The hot melt adhesive composition of the present invention comprises as components thereof a mixture of the following ingredients:

- 10           a.     A blend of syndiotactic polypropylene (SPP) polymer and atactic poly- $\alpha$ -olefin (APAO) in the amount of about 15% to 80% by weight, preferably in the amount of about 25% to 60% by weight, and most preferably in an amount of from about 35% to 55% by weight, said blend having a SPP to APAO ratio from about 10% by weight of SPP and 90% by
- 15           weight of APAO to about 90% by weight of SPP and 10% by weight of APAO; said blend having a most preferred ratio of 20% SPP and 80% APAO; said SPP having a density of about 0.85 g/cc to 0.92 g/cc and a melt flow rate of equal to or greater than 1 g/10 min and a r value equal to or
- 20           greater than 70%; and said APAO having a density of about 0.85 g/cc to 0.89 g/cc and a glass transition temperature (Tg) of from about -5 to -40 °C and a weight average molecular weight (Mw) of from about 4,000 g/mol to about 150,000 g/mol.;
- b.     A compatible tackifier in the amount of 15% by weight to 65% by weight, preferably in the amount of 30% by weight to 50% by weight;
- 25           c.     About 0% to 35% by weight, preferably about 5% to 30% by weight, of a plasticizer;

- d. About 0% to 3% by weight of a stabilizer or antioxidant.
- e. Optionally, about 0% to 30% by weight, preferably about 0% to 18% by weight, of a wax;

the components of the composition adding up to 100% by weight. The adhesive  
5 composition may contain other components such as a filler and/or a colorant and/or  
a fluorescing agent and/or another polymer that can modify the adhesive properties  
of the above basic adhesive composition, as desired.

### BRIEF DESCRIPTION OF THE DRAWINGS

10 Fig. 1a illustrates schematically an undesired poor spiral spray pattern for  
the adhesive of the present invention;

Fig. 1b illustrates schematically a desired perfect spiral spray pattern for the  
adhesive of the present invention;

15 Fig. 2 illustrates a schematic perspective view of a corrugated box having  
the adhesive of the present invention applied to top flaps thereof; and

Fig. 3 illustrates the corrugated box of Fig. 2 sealed by the adhesive of the  
present invention.

### DETAILED DESCRIPTION OF THE INVENTION

20 In accordance with the present invention, a hot melt adhesive composition is  
produced, comprising as the primary polymer components a blend of syndiotactic  
polypropylene (SPP) polymer and an atactic poly- $\alpha$ -olefin (APAO) in the amount  
of about 15% to 80% by weight, preferably in the amount of about 25% to 60% by  
weight, and most preferably in an amount of from about 35% to 55% by weight,  
25 said blend having a SPP to APAO ratio from about 10% by weight of SPP and 90%  
by weight of APAO to about 90% by weight of SPP and 10% by weight of APAO,  
said blend having a most preferred ratio of 20% SPP and 80% APAO. The hot melt  
adhesive composition of the present invention also includes about 15% to 65% by  
weight, preferably about 30% to 50% by weight, of tackifier, about 0% to 30% by

weight, preferably about 5% to 30% by weight, of plasticizer, about 0% to 30% by weight, preferably about 0% to 18% by weight, of wax and about 0% to 3% by weight of stabilizer or antioxidant. Optional components such as filler, colorant, blowing agent, fluorescing agent and the like can be added to the basic composition  
5 to modify its properties, as desired.

The hot melt composition of the present invention includes a SPP polymer. The art of preparing SPP polymers have been disclosed in U.S. Patent 3,305,538 and 3,258,455 to Natta et al, U.S. Patent 4,892,851 to Ewen et al, U.S. Patent 5,270,410 to Job, U.S. Patent 5,340,917 to Eckman et al, U.S. Patent and U.S.  
10 Patent 5,476,914 to Ewen et al., the entire disclosures of which are hereby incorporated by reference. While syndiotactic propylene homopolymer can be used in the hot melt composition of the present invention, syndiotactic polypropylene copolymers are preferred. Suitable SPP copolymers can be prepared by copolymerization of propylene with other unsaturated olefin monomers containing  
15 2 to 10 carbon atoms, which include, but are not limited to, ethylene, butene-1, pentene-1, 4-methyl pentene-1, hexene-1 and octene-1. These homopolymers and copolymers can be manufactured with any prior art process herein described above. However, the polymers prepared by using method disclosed in U.S. Patent 5,476,914 with metallocene catalyst system are preferred. Compared with other  
20 methods, the SPP polymers prepared with metallocene catalyst will have better stereo-regularity, narrower molecular weight distribution and more uniform comonomer distribution, which lead to better physical and mechanical properties and superior processibility. The most preferred type of SPP polymers is metallocene catalyzed copolymer of propylene with ethylene or butene-1 having  
25 ethylene or butene-1 comonomer content ranging from about 2% to 20% by weight.

The SPP polymers useful in the present invention preferably have a r value equal to or greater than 70%, more preferably greater than 80% and most preferably greater than 85%. The said polymers generally have a density in a range from about 0.85 g/cc to about 0.90 g/cc and preferably from 0.86 g/cc to 0.88 g/cc at the room

temperature as measured per ASTM D-1505 test method. The polymer also has a melt flow rate (MFR), which is inversely related to weight average molecular weight  $M_w$ , equal to or greater than 1g/10 min., preferably between 20 – 500 g/10 min. and more preferably between 20 – 200 g/10 min., as measured per ASTM D-1238 test method. Examples of polymers of this type are available under trade designation Fina EOD98-05, Fina EOD99-19, Fina EOD 96-28, Fina EOD 96-30, Fina EOD 99-08 and Fina EOD 96-34 from ATOFINA Petrochemicals, Inc., Houston, TX.

The APAO component of the blend useful in the present invention consists of several different categories of atactic, low molecular weight, low melt viscosity, and substantially amorphous propylene based polymers. The term “substantially amorphous” is defined herein as having a degree of crystallinity less than 30%, as determined by differential scanning calorimetry (DSC) against a highly crystalline polypropylene standard. These polymers can be either homopolymers of propylene or copolymers of propylene with one or more  $\alpha$ -olefin comonomer, such as, for example, ethylene, butene-1, hexene-1 and octene-1. The average weight molecular weight of the APAO polymers in the scope of the present invention is in the range of from about 4,000 to about 150,000 g/mol, preferably from about 10,000 to about 100,000 g/mol. The said polymers have advantageously a softening point between about 80 and 170 °C and a glass transition temperature from about -5 to -40 °C. Although any APAO polymer falling in the range of physical properties herein described above can be used, the most preferred APAO is selected from the group consisting of propylene homopolymer, propylene-ethylene copolymer, propylene-butene-1 copolymer and propylene-ethylene-butene-1 terpolymer. The APAO polymers of the types herein described above are commercially available from Eastman Chemical Company, Kingsport, TN, under the trade name designation Eastoflex or from Huntsman Corporation, Houston, TX, under the trade name designation Rexflex or from Degussa Corporation, Passipanny, NJ, under the trade name designation Vestoplast.

The tackifying resins or tackifiers which are used in the hot melt adhesives of the present invention are those which extend adhesive properties and improve specific adhesion. As used herein, the term "tackifying resin" include:

- 5 (a) aliphatic and cycloaliphatic petroleum hydrocarbon resins having Ring and Ball softening points of from 10 °C to 160 °C, as determined by ASTM method E28-58T, the latter resins resulting from the polymerization of monomers consisting primarily of aliphatic and/or cycloaliphatic olefins and diolefins; also included are the hydrogenated aliphatic and cycloaliphatic petroleum hydrocarbon resins; examples of such  
10 commercially available resins based on a C5 olefin fraction of this type are piccotac 95 tackifying resin sold by Hercules Corp. and Escoreze 1310LC sold by ExxonMobil Chemical Company;
- (b) Aromatic petroleum hydrocarbon resins and the hydrogenated derivatives thereof;
- 15 (c) Aliphatic/aromatic petroleum derived hydrocarbon resins and the hydrogenated derivatives thereof;
- (d) Aromatic modified cycloaliphatic resins and the hydrogenated derivatives thereof;
- 20 (e) Polyterpene resins having a softening point of from about 10°C to about 140°C, the latter polyterpene resins generally resulting from the polymerization of terpene hydrocarbons, such as the mono-terpene known as pinene, in the presence of Friedel-Crafts catalysts at moderately low temperatures; also included are the hydrogenated polyterpene resins;
- 25 (f) Copolymers and terpolymers of natural terpenes, e.g. styrene/terpene,  $\alpha$ -methyl styrene/terpene and vinyl toluene/terpene;
- (g) natural and modified rosin such as, for example, gun rosin, wood rosin, tall-oil rosin, distilled rosin, hydrogenated rosin, dimerized rosin and polymerized rosin;

(h) glycerol and pentaerythritol esters of natural and modified rosin, such as, for example, the glycerol ester of pale wood rosin, the glycerol ester of hydrogenated rosin, the glycerol ester of polymerized rosin, the pentaerythritol ester of pale wood rosin, the pentaerythritol ester of hydrogenated rosin, the pentaerythritol ester of tall-oil rosin, and the phenolic modified pentaerythritol ester of rosin;

(i) phenolic-modified terpene resins such as, for example, the resin product resulting from the condensation in an acidic medium of a terpene and a phenol;

Mixtures of two or more of the above described tackifying resins may be required for some formulations. Although a range of 15% to 65% by weight tackifying resin may be used, the preferred amount is from about 30% to about 50% by weight. Tackifying resins which are useful for the present invention can perhaps include polar tackifying resins, however, the choice of available polar tackifying resins is limited in view of the fact that many of the polar resins appear only partially compatible with SPP and APAO polymers.

As noted above, tackifying resins which are useful within the scope of the present invention comprise about 15% to 65% by weight. Preferably, the tackifying resins can be selected from any of the nonpolar types, which are commercially available. Preferred resins are aliphatic petroleum hydrocarbon resins examples of which are based on C5 olefins such as Hercotac 1148 available from Hercules Corp. Most preferred are nonpolar products which are hydrogenated DCPD based or aromatically modified derivatives thereof with softening points above 70 °C. Examples of such resins are Escoreze 5400 and Escoreze 5600 sold by ExxonMobil Chemical company.

A plasticizer can be present in the composition of the present invention in amounts of 0% to about 35% by weight, preferably from about 5% to about 30%, in order to provide desired viscosity control and to impart flexibility. A suitable



plasticizer may be selected from the group which includes the usual plasticizing oils, such as mineral oil, but also olefin oligomers and low molecular weight polymers, as well as vegetable and animal oils and derivatives of such oils. The petroleum derived oils which may be employed are relatively high boiling materials containing only a minor proportion aromatic hydrocarbons. In this regard, the aromatic hydrocarbons should preferably be less than 30% and more particularly less than 15% of the oil, as measured by the fraction of aromatic carbon atoms. More preferably, the oil may be essentially non-aromatic. The oligomers may be polypropylenes, polybutenes, hydrogenated polyisoprenes, hydrogenated polybutadiens, or the like having average molecular weight between about 350 and about 10,000. Suitable vegetable and animal oils include glycerol esters of the usual fatty acids and polymerization products thereof. Other useful plasticizers can be found in the families of conventional dibenzoate, phosphate, phthalate esters, as well as esters of mono- or polyglycols. Examples of such plasticizers includes, but are not limited to dipropylene glycol dibenzoate, pentaerythritol tetrabenzoate, 2-ethylhexyl diphenyl phosphate, polyethylene glycol 400-di-2-ethylhexoate; butyl benzyl phthalate, dibutyl phthalate and dioctylphthalate. The plasticizers that finds usefulness in the present invention can be any number of different plasticizers but the inventors have discovered that mineral oil and liquid polybutenes having average molecular weight less than 5,000 are particularly advantageous. As will be appreciated, plasticizers have typically been used to lower the viscosity of the overall adhesive composition without substantially decreasing the adhesive strength and/or the service temperature of the adhesive as well as to extend the open time and to improve flexibility of the adhesive.

Waxes can be used to reduce the melt viscosity of the hot melt adhesive composition. Although amounts varying from about 0% to 35% by weight may be used in the composition of the present invention, the preferred amounts are between 0% to 18% by weight. These waxes can also effect the set-up time and the softening point of the adhesive. Among the useful waxes are:

1. low molecular weight, that is, number average molecular weight (Mn) equal to 500 – 6000, polyethylene having a hardness value, as determined by ASTM method D-1321, of from about 0.1 to 120, having an ASTM softening point of from about 65 °C to 140 °C;

5 2. petroleum waxes such as paraffin wax having a melting point of from about 50 °C to 80 °C and microcrystalline wax having a melting point of from about 55 °C to 100 °C, the latter melting points being determined by ASTM method D127-60;

10 3. synthetic waxes made by polymerizing carbon monoxide and hydrogen such as Fischer-Tropsch wax; and

4. polyolefin waxes. As used herein, the term “polyolefin wax” refers to those polymeric or long-chain entities comprised of olefinic monomer units. This type of materials are commercially available from Eastman Chemical Co. under the trade name designation “Epolene”. The materials which are preferred for use in the composition of the present invention have a Ring and Ball softening point of from about 100°C to 170°C. As should be understood, each of these wax diluents is solid the room temperature.

15 Other substances which include hydrogenated animal, fish and vegetable fats and oils such as hydrogenated tallow, lard, soya oil, cottonseed oil, castor oil, menhadin oil, cod liver oil, and the like, and which are solid at the room temperature by virtue of their being hydrogenated, have also been found to be useful with respect to functioning as a wax diluent equivalent. These hydrogenated materials are often referred to in the adhesive industry as “animal or vegetable waxes”.

25 The present invention may include a stabilizer in an amount of from about 0% to about 3% by weight. Preferably from about 0.1% to 1% of a stabilizer is incorporated into the composition. The stabilizers which are useful in the hot melt adhesive compositions of the present invention are incorporated to help protect the

polymers noted above, and thereby the total adhesive system, from the effects of thermal and oxidative degradation which normally occurs during the manufacture and application of the adhesive as well as in the ordinary exposure of the final product to the ambient environment. Among the applicable stabilizers are high  
5 molecular weight hindered phenols and multifunction phenols, such as sulfur and phosphorous-containing phenols. Hindered phenols are well known to those skilled in the art and may be characterized as phenolic compounds that also contain sterically bulky radicals in close proximity to the phenolic hydroxyl group thereof. In particular, tertiary butyl groups generally are substituted onto the benzene ring in  
10 at least one of the ortho positions relative to the phenolic hydroxyl group. The presence of these sterically bulky substituted radicals in the vicinity of the hydroxyl group serves to retard its stretching frequency and correspondingly, its reactivity; this steric hindrance thus providing the phenolic compound with its stabilizing properties. Representative hindered phenols include:

15 1,3,5-trimethyl-2,4,6-tris(3-5-di-tert-butyl-4-hydroxybenzyl) benzene;  
pentaerythritol tetrakis-3(3,5-di-tert-butyl-4-hydroxyphenyl) propionate;  
n-octadecyl-3(3,5-di-tert-butyl-4-hydroxyphenyl) propionate;  
4,4'-methylenebis(4-methyl-6-tert butylphenol);  
2,6-di-tert-butylphenol;  
20 6-(4-hydroxyphenoxy)-2,4-bis(n-octylthio)-1,3,5-triazine;  
2,3,6-tris(4-hydroxy-3,5-di-tert-butyl-phenoxy)-1,3,5-triazine;  
di-n-octadecyl-3,5-di-tert-butyl-4-hydroxybenzylphosphonate;  
2-(n-octylthio)ethyl-3,5-di-tert-butyl-4-hydroxybenzoate; and  
sorbitol hexa-3(3,5-di-tert-butyl-4-hydroxy-phenyl) propionate.

25 Especially preferred as a stabilizer is pentaerythritol tetrakis-3(3,5-di-tert-butyl-4-hydroxyphenol) propionate.

The performance of these stabilizers may be further enhanced by utilizing, in conjunction therewith; (1) synergists such as, for example, thiodipropionate esters

and phosphites; and (2) chelating agents and metal deactivators such as, for example, ethylenediaminetetraacetic acid, salts thereof, and disalicylalpropylenediimine.

It should be understood that other optional additives may be incorporated into the adhesive composition of the present invention in order to modify particular  
5 physical properties. These may include, for example, such materials as inert colorants (e.g. titanium dioxide), fillers, fluorescent agents, surfactants, other types of polymers, etc. Typical fillers include talc, calcium carbonate, clay, silica, mica, wollastonite, feldspar, aluminum silicate, alumina, hydrated alumina, glass  
10 microspheres, ceramic microspheres, thermoplastic microspheres, baryte and wood flour. Surfactants are particularly important in hygienic disposable nonwovens because they can dramatically reduce the surface tension, for example, of the adhesive applied to diaper core, thereby permitting quicker transport and subsequent absorption of urine by the core.

The hot melt adhesive composition of the present invention may be  
15 formulated using pre-mixed SPP/APAO blend, but it is preferred to introduce the polymers as separate components during the compounding process by any of the mixing techniques known in the art. A representative example of the prior art mixing procedure involves placing all the components, except the SPP polymer, in a jacketed mixing kettle equipped with a rotor, and thereafter raising the  
20 temperature of the mixture to a range from 160 °C to 200 °C to melt the contents. It should be understood that the precise temperature to be used in this step would depend on the melting points of the particular ingredients. The SPP polymer is subsequently introduced to the kettle under agitation and the mixing is allowed to continue until a consistent and uniform mixture is formed. The content of the kettle  
25 is protected with inert gas such as carbon dioxide or nitrogen during the entire mixing process.

The resulting hot melt adhesives may be then applied to substrates using a variety application technique. Examples includes hot melt glue gun, hot melt slot-die coating, hot melt wheel coating, hot melt roller coating, melt blown coating,

spiral spray and the like. In a preferred embodiment, the hot melt adhesive is sprayed onto a substrate using spiral spray, which is a preferred technique to produce a filamentary spiral pattern for elastic attachment and construction in diaper manufacturing. In one example, a hot melt coater is equipped with a disc like  
5 coating die which has a nozzle tip in the center. The tip is surrounded with a series of inclined orifices for hot air jets to pass through. The hot melt adhesive is pumped out of the nozzle in the form of a fine filament. The filament is then rotated by high-velocity hot air jets coming out of the orifices, thereby producing a helical pattern from a single strand of adhesive. It is not the intent of this invention to  
10 provide a full description of spray techniques and the details can be found in the literature.

The adhesive composition of the present invention may be used in a number of applications such as, for example, in disposable nonwoven hygienic articles, paper converting, flexible packaging, wood working, carton and case sealing,  
15 labeling and other assembly applications. Particularly preferred applications include disposable diaper and feminine sanitary napkin construction, diaper and adult incontinent brief elastic attachment, diaper and napkin core stabilization, diaper backsheet lamination, industrial filter material conversion, surgical gown and surgical drape assembly, etc.

20

## TESTS AND MATERIALS

Brookfiled viscosity was tested according to ASTM D-3236 Method at 350°F.

Ring & Ball softening point was determined with an automated Herzog unit  
25 according to ASTM E-28 method.

Peel strength was measured in 180° geometry with a tensile tester (Instron Model 55R1122) in the controlled atmospheric environment (20 °C and 50% relative humidity). Prior to the test, the specimens were conditioned at the controlled environment for approximately 12 hours to ensure the reproducibility

and accuracy of the data. The test was done at a cross-head speed of 12"/min. The average peel value of six replicates, normalized to g/in unit, was reported as the peel strength.

Creep Resistance test was carried out with the laminated specimens of Examples 1 – 3 herein later described. The specimen, cut to 300 mm in length, was stretched out completely and its ends were securely attached to a piece of rigid corrugated paperboard. A length of 200 mm was marked and the elastic strands were cut at the marks. The specimen was then placed in an air-circulating oven at 100 °F. Under these conditions, the elastic strands under stretch can retreat to a certain distance. The distance between the ends was measured after an hour. The ratio of the final length to the initial length, defined as Creep Retention and expressed in percentage (%), is a measure of the ability of the adhesive to hold the elastic strands.

Sprayability was measured empirically on a Meltex CT225 (Nordson) hot melt coater. The coating conditions varied depending on the adhesive sample.

Fina EOD 98-05 and EOD 99-19 are propylene-ethylene copolymer type of SPPs prepared by using single-site metallocene catalyst system as that disclosed in US Patent 5,476,914. The polymers contain about 10% by weight of ethylene and are commercially available from AtoFina Petrochemicals Inc, Houston, TX. They both have a r value of about 95%, a density of 0.87 g/cc and a DSC melting point of 130 °C. Fina EOD 98-05 has a melt flow rate of about 20 g/10 min. as determined by using ASTM Method D-1238 and Fina EOD 99-19 has a melt flow rate of 25g/10min.

N01096-05, obtained from AtoFina Petrochemicals, is a developmental propylene-ethylene copolymer SPP having about 10% by weight ethylene. It has a r value of about 95%, a density of 0.87 g/cc and a melt flow rate of 118 g/10min.

Rexflex RT2180 is an atactic homopolypropylene type of APAO having a Brookfield viscosity of about 8,000 cP at 190 °C, a Tg of about –20 °C and a softening point of about 157 °C. It is available from Huntsman Corporation.

Rexflex RT2280, also available from Huntsman, is an atactic propylene-ethylene copolymer type of APAO having a Brookfield viscosity of about 8,000 cP at 190 °C, a Tg of about -22 °C and a softening point of about 146 °C.

5 Rexflex RT2780, also available from Huntsman, is an atactic propylene-butene-1 copolymer type of APAO having a Brookfield viscosity of about 8,000 cP at 190 °C, a Tg of about -23 °C and a softening point of about 110 °C.

Eastoflex P1010, obtained from Eastman Chemical Company, Kingsport, TN, is an atactic homopolypropylene type of APAO having a Brookfield viscosity of about 1,000 cP at 190 °C, a Tg of about -10 °C and a softening point of about  
10 150 °C.

Eastoflex M1058, also obtained from Eastman Chemical Company, is an atactic homopolypropylene/copolymer mixture type of APAO having a Brookfield viscosity of about 5,800 cP at 190 °C and a softening point of about 151 °C.

Eastoflex E-1200, also obtained from Eastman Chemical Company, is an  
15 atactic propylene-ethylene copolymer type of APAO having a Brookfield viscosity of about 12,000 cP at 190 °C, a Tg of about -28 °C and a softening point of about 135 °C.

Escorez 5380, available from Exxon, is a very light color, hydrogenated cycloaliphatic hydrocarbon tackifier having an R&B softening point of about 80 °C.

20 Hercotac 1148 is a C5 aliphatic hydrocarbon resin having a R&B softening point of 100 °C. It is available from Hercules Corporation.

Eastotac H130R, available from Eastman Chemical Company, is a partially hydrogenated C5 hydrocarbon resin having a R&B softening point of 130 °C.

Sylvaroz ZT 105 is styrenated polyterpene tackifier having a R&B softening  
25 point of about 105 °C. It is available from Arizona Chemical Company, Jacksonville, FL.

Kaydol oil is an USP grade white mineral oil plasticizer, obtained from Krompton Corporation, Greenwich, CT.

Pennznap 500, available from Pennzoil Products Co., is an industrial mineral oil plasticizer.

Marcus 300, available from Marcus Oil & Chemicals, Inc., is a synthetic polyethylene wax having a melting point of about 240 °F.

5 The invention is further illustrated by way of the examples which are set forth below.

#### EXAMPLES 1 – 3

Hot melt adhesive examples of 1 – 3 shown in Table 1 were prepared with  
10 the ingredients and mixing procedures described herein above. A total of 2000 grams each were made and the mixing was carried out at 350 - 375 °F under carbon dioxide atmosphere in a laboratory type of mixer what consists of a propeller powered by a motor, a heating mantle, a temperature control unit and a container of about 1 gallon in size. The appropriate amounts of each component, calculated  
15 according to the ratios shown in the table, except the SPP polymer, were added to the container. The temperature of the container was then raised to melt the contents. After the ingredients in the container were completely melted, the motor was turned on to start agitation. Subsequently, the SPP polymer component was introduced, and mixed thoroughly therein. The adhesive examples of 1 – 3 are especially useful  
20 as elastic attachment adhesive for elastic attachment applications.

Brookfield Viscosity, R&B Softening Point and Creep Retention tests were carried out on Examples 1 – 3 according to the procedures herein described above. The room temperature tack was judged by the adhesive's stickiness to human fingers. Specimens for Creep Retention test were formed by using spiral spray  
25 technique on Meltex CT225 hot melt coater which was fitted with a 0.018" spiral spray nozzle. To prepare the specimen, three elastic strands (Lycra 740), which were stretched to 300% elongation, were laminated between a layer of 1.0 mil thick polyethylene film and a layer of polypropylene spunbond nonwoven fabric. Sprayability was evaluated during the coating process by observing the shape of the



spiral pattern. The sprayability was deemed acceptable if a good spiral pattern as that depicted in Figure 1b was observed; otherwise, it was deemed unacceptable (Figure 1a). Adhesives were spiral sprayed at 18 g/m<sup>2</sup> coating weight with 0.25 seconds open time and 1 bar compression at the nip rolls and the application temperature was set at 375 °F. The adhesives of Examples of 1 – 3 were found to have almost no room temperature tack, low melt viscosity, good sprayability and good creep retention properties.

TABLE 1. EXAMPLES 1 – 3

Ingredients	Percent (%) by weight		
	1	2	3
Fina EOD 98-05	10.0	-	-
Fina EOD 99-19	-	10.0	22.0
Eastoflex P1010	40.0	-	-
Rexflex RT2280	-	40.0	-
Rexflex RT2180	-	-	15.0
Pennznep 500	10.0	-	25.0
Kaydol Oil	-	10.0	-
Eastotac H130R	39.5	39.5	-
Sylvaros ZT105	-	-	25.0
Marcus 300	-	-	12.5
Antioxidant	0.5	0.5	0.5
Room Temperature Tack	None	None	None
Brookfield Vis. (cP)	3350	9300	7000
R&B Softening Point (°F)	285	288	260
Sprayability	Good	Good	Good
Creep Retention (%)	66	80	72

10

## EXAMPLES 4 - 8

Examples of 4 – 8 were formulated by using the same procedure as herein described above and the ingredients listed in Table 2. These formulations are particularly suited as laminating adhesives for a variety flexible packaging applications and as construction adhesives for disposable nonwoven applications.

15

When used as such, the peel strength is the most important measure of adhesive performance. The peel strength of Examples 4 – 8 was measured and the results were also reported in Table 2. The specimens for the peel strength measurement were prepared by laminating the same polyethylene film and polypropylene spunbond nonwoven fabric as in Examples 1 – 3 with controlled fiberization coating technique, which is another form of air-aided spray application, on CT225 hot melt coated equipped with three ITW controlled fiberization nozzles. The adhesive was applied in the amount of 3 g/m<sup>2</sup> at 325 - 375 °F application temperature and 0.5 seconds open time. The precise application temperature for each sample varied within the temperature range to optimize the spray pattern. The adhesives of Examples of 4 - 8 were found to have almost no or very low room temperature tack, low melt viscosity, good sprayability and substrate-destruct film/nonwoven bond.

TABLE 2. EXAMPLES 4 - 8

Ingredients	Percent (%) by Weight				
	4	5	6	7	8
Fina EOD 99-19 (25 MFR)	10.0	10.0	10.0	-	-
N01096-05 (118 MFR)	-	-	-	10.0	10.0
Rexflex RT 2180	40.0	-	-	-	-
Rexflex RT 2780	-	40.0	-	-	-
Eastoflex M1058	-	-	40.0	-	-
Eastoflex E-1200	-	-	-	35.0	30.0
Kaydol Oil	10.0	15.0	10.0	12.5	15.0
Hercotac 1148	39.5	39.5	39.5	42.0	44.5
Antioxidant	0.5	0.5	0.5	0.5	0.5
Room Temperature Tack	None	Low	Low	Low	Low
Softening Point (°F)	297	258	283	244	240
Vis. @ 350 °F (cP)	6500	5800	5030	4875	3500
Sprayability	Good	Good	Good	Good	Good
Peel Strength (g/25 mm)	365	380	322	286	245

## EXAMPLE 9

The adhesive in this Example 9 was prepared by using the same procedure herein described above and ingredients consisting of 35.0% by weight Fina EOD 99-19 SPP polymer, 10.0% by weight Eastoflex P1010 APAO, 20.0% by weight  
5 Kaydol oil, 34.5% by weight Escorez 5380 tackifier and 0.5% by weight antioxidant. The adhesive sample has a Brookfield Viscosity of 30,700 cP at 375 °F and a softening point of 251 °F. It is particularly useful for case and carton sealing applications. To illustrate the use for such application, reference is made to Figs. 2 and 3 herein where single adhesive beads of about 2 mm in diameter, illustrated as  
10 21a and 21b in Figure 2, was applied by hand across the upper surface of top flaps 22a and 22b of a corrugated box 20 as shown in the figure. Immediately after the adhesive application, the top flaps 22a and 22b of box 20 were folded over and brought into contact with bottom flaps 23a and 23b to seal the box 20. The flaps 22a, 22b, 23a and 23b were then held together by pressure means for approximately  
15 1 minute to seal box 20 as shown in Fig. 3. The adhesive yielded a fiber tearing bond in about 20 minutes after the adhesive application.

Without deviating from the spirit and scope of the present invention, many embodiments and variations can be made by using the components disclosed herein above.

## CLAIMS

We claim:

1. A hot melt adhesive composition comprising
  - (a) about 15% to about 70% by weight of a blend of syndiotactic polypropylene (SPP) polymer and amorphous poly- $\alpha$ -olefin (APAO) polymer, said blend having a SPP to APAO ratio from about 10% by weight of SPP and 90% by weight of APAO to about 90% by weight of SPP and 10% by weight of APAO;
  - (b) about 15% to 65% by weight of a tackifier;
  - (c) about 0% to 35% by weight of a plasticizer;
  - (d) about 0% to 3% by weight of a stabilizer.
2. The composition of claim 1 wherein said SPP polymer has a density of about 0.85 g/cc to 0.92 g/cc and a melt flow rate of equal to or greater than 1 g/10min and a r value equal to or greater than 70%.
3. The composition of claim 1 wherein said APAO polymer has a density of about 0.85 g/cc to 0.89 g/cc and a glass transition temperature (T<sub>g</sub>) of from about -5 to -40 °C and a weight average molecular weight (M<sub>w</sub>) of from about 4,000 g/mol to about 150,000 g/mol.
4. The composition of claim 1 wherein the SPP polymer is a homopolymer of propylene having a density of about 0.85 to 0.92 g/cc and a melt flow rate equal to or greater than 1 g/10min.
5. The composition of claim 1 wherein the SPP polymer is a copolymer of propylene and at least one  $\alpha$ -olefin comonomer having the following molecular structure:
$$\text{R-CH=CH}_2$$
where R is a hydrogen H, or an alkyl or an aryl radical, said  $\alpha$ -olefin consisting of from about 2% to 30% by weight of copolymer and having a density of about 0.85 to 0.90 g/cc and a melt flow rate of equal to or great than 1g/min.

6. The composition of claim 5 wherein the  $\alpha$ -olefin comonomer is selected from the group consisting of ethylene, butene-1 and hexene-1.

7. The composition of claim 1 wherein the APAO polymer is a homopolymer or a copolymer of propylene and at least one  $\alpha$ -olefin comonomer having the following molecular structure:

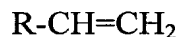

5 where R is a hydrogen H, or an alkyl or an aryl radical .

8. The composition of claim 7 wherein the  $\alpha$ -olefin comonomer is selected from the group consisting of ethylene, butene-1 and hexene-1.

9. The composition of claim 1 wherein the tackifier is selected from the group consisting of aliphatic and cycloaliphatic hydrocarbon resins and their hydrogenated derivatives, aromatic and hydrogenated aromatic hydrocarbon resins, aromatically modified aliphatic or cycloaliphatic resins and their hydrogenated  
5 derivatives, polyterpene and styrenated polyterpene resins.

10. The composition of claim 9 wherein the tackifier has a R&B softening point equal to or greater than 80 °C.

11. The composition of claim 10 wherein the tackifier is a C-5 aliphatic hydrocarbon resin.

12. The composition of claim 1 wherein the plasticizer is selected from the group consisting of mineral oil and liquid polybutene.

13. The composition of claim 12 wherein the mineral oil has less than 30% aromatic carbon atoms.

14. The composition of claim 1 wherein the adhesive composition further comprises a wax in the amount up to 30% by weight.

15. The composition of claim 14 wherein said wax is selected from the group consisting of petroleum waxes, low molecular weight polyethylene and polypropylene, synthetic waxes and polyolefin waxes.

16. The composition of claim 15 wherein the said wax is a low molecular weight polyethylene having a number average molecular weight of about 400 to about 6,000 g/mol.

17. The composition of claim 1 wherein the adhesive composition further includes a filler in the amount up to 60% by weight.

18. The composition of claim 17 wherein said filler is selected from the group consisting of talc, calcium carbonate, clay, silica, mica, wollastonite, feldspar, aluminum silicate, alumina, hydrated alumina, glass microsphere, ceramic microsphere, thermoplastic microsphere, baryte and wood flour.

19. The composition of claim 1 wherein the adhesive composition further includes a colorant.

20. The composition of claim 1 wherein the adhesive composition further includes another polymer.

21. A corrugated box article bonded with the adhesive composition of claim 1.

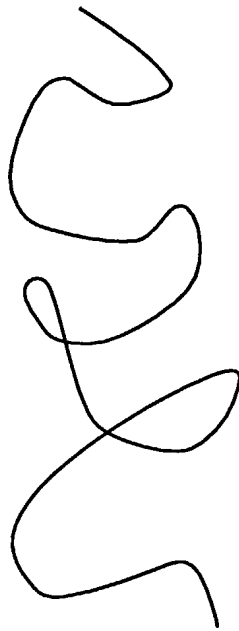

FIG. 1(a)

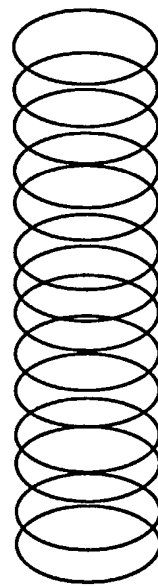

FIG. 1(b)

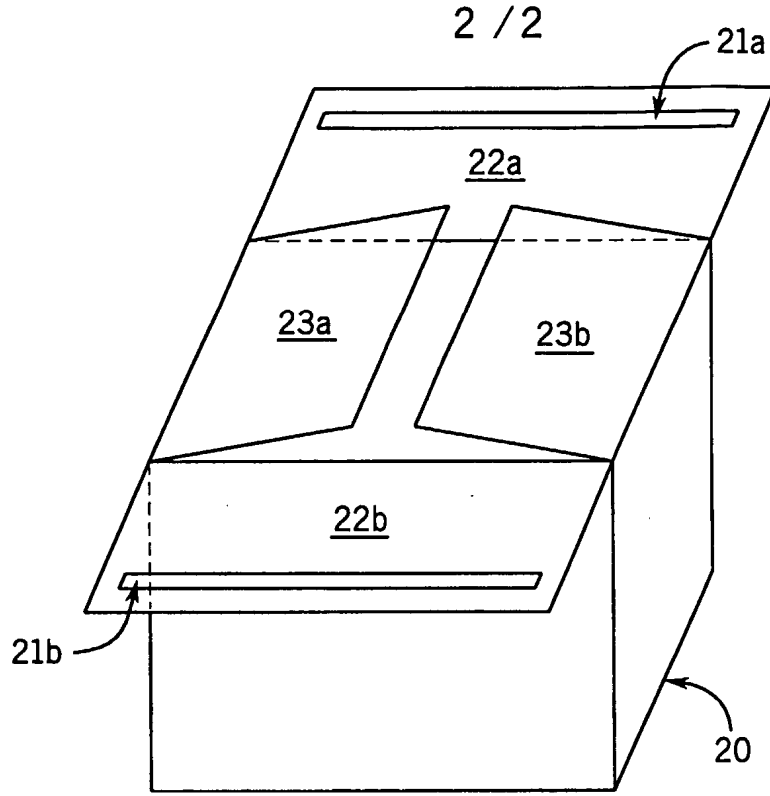

FIG. 2

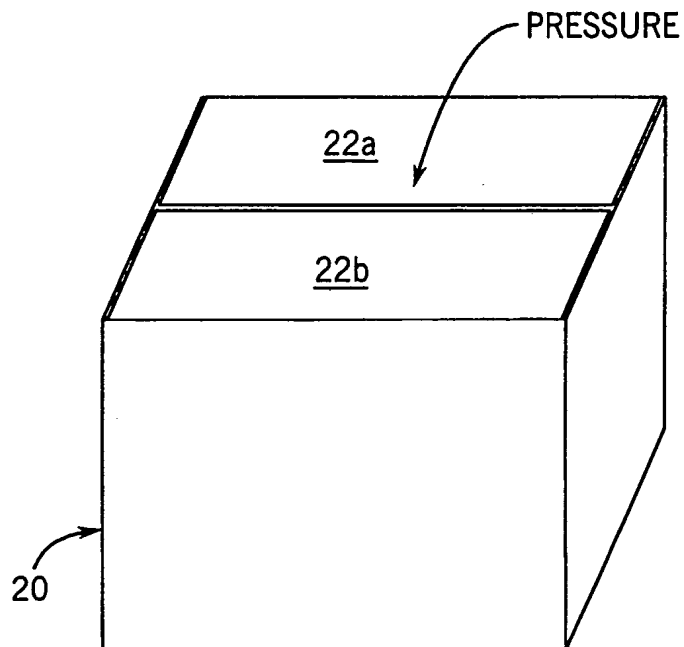

FIG. 3



## INTERNATIONAL SEARCH REPORT

 International Application No  
 PCT/US 02/26297

**A. CLASSIFICATION OF SUBJECT MATTER**  
 IPC 7 C09J123/10

According to International Patent Classification (IPC) or to both national classification and IPC

**B. FIELDS SEARCHED**
 Minimum documentation searched (classification system followed by classification symbols)  
 IPC 7 C09J C08L

Documentation searched other than minimum documentation to the extent that such documents are included in the fields searched

Electronic data base consulted during the international search (name of data base and, where practical, search terms used)

EPO-Internal, PAJ, WPI Data

**C. DOCUMENTS CONSIDERED TO BE RELEVANT**

Category *	Citation of document, with indication, where appropriate, of the relevant passages	Relevant to claim No.
A	US 4 998 928 A (MALETSKY ALBERT ET AL) 12 March 1991 (1991-03-12) column 1, line 58 -column 2, line 5 ---	1-21
A	EP 0 931 814 A (FINA RESEARCH) 28 July 1999 (1999-07-28) example 21; table 9 ---	1-21
A	PATENT ABSTRACTS OF JAPAN vol. 2000, no. 10, 17 November 2000 (2000-11-17) & JP 2000 191852 A (MITSUI CHEMICALS INC), 11 July 2000 (2000-07-11) abstract ---	1-21
A	WO 94 04625 A (EXXON CHEMICAL PATENTS INC) 3 March 1994 (1994-03-03) examples 6-13 ---	1-21
	-/--	

 Further documents are listed in the continuation of box C.

 Patent family members are listed in annex.

\* Special categories of cited documents :

- \*A\* document defining the general state of the art which is not considered to be of particular relevance
- \*E\* earlier document but published on or after the international filing date
- \*L\* document which may throw doubts on priority claim(s) or which is cited to establish the publication date of another citation or other special reason (as specified)
- \*O\* document referring to an oral disclosure, use, exhibition or other means
- \*P\* document published prior to the international filing date but later than the priority date claimed

- \*T\* later document published after the international filing date or priority date and not in conflict with the application but cited to understand the principle or theory underlying the invention
- \*X\* document of particular relevance; the claimed invention cannot be considered novel or cannot be considered to involve an inventive step when the document is taken alone
- \*Y\* document of particular relevance; the claimed invention cannot be considered to involve an inventive step when the document is combined with one or more other such documents, such combination being obvious to a person skilled in the art.
- \*G\* document member of the same patent family

Date of the actual completion of the international search

2 December 2002

Date of mailing of the international search report

27/12/2002

Name and mailing address of the ISA

 European Patent Office, P.B. 5818 Patentlaan 2  
 NL - 2280 HV Rijswijk  
 Tel. (+31-70) 340-2040, Tx. 31 651 epo nl,  
 Fax: (+31-70) 340-3016

Authorized officer

Schmidt, H

INTERNATIONAL SEARCH REPORT

International Application No  
PCT/US 02/26297

C.(Continuation) DOCUMENTS CONSIDERED TO BE RELEVANT		
Category °	Citation of document, with indication, where appropriate, of the relevant passages	Relevant to claim No.
A	EP 0 697 436 A (MONTELL TECHNOLOGY COMPANY BV) 21 February 1996 (1996-02-21) examples 3-5 -----	1-21

## INTERNATIONAL SEARCH REPORT

International Application No

PCT/US 02/26297

Patent document cited in search report		Publication date	Patent family member(s)	Publication date
US 4998928	A	12-03-1991	US 4939202 A	03-07-1990
EP 0931814	A	28-07-1999	EP 0931814 A1	28-07-1999
			AU 2829099 A	09-08-1999
			WO 9937711 A2	29-07-1999
			EP 1049741 A2	08-11-2000
			JP 11315175 A	16-11-1999
			US 6348272 B1	19-02-2002
			US 2002055561 A1	09-05-2002
JP 2000191852	A	11-07-2000	NONE	
WO 9404625	A	03-03-1994	US 5317070 A	31-05-1994
			CA 2143124 A1	03-03-1994
			DE 69321478 D1	12-11-1998
			DE 69321478 T2	15-04-1999
			EP 0656925 A1	14-06-1995
			ES 2123659 T3	16-01-1999
			JP 8500369 T	16-01-1996
			WO 9404625 A1	03-03-1994
EP 0697436	A	21-02-1996	IT 1274606 B	18-07-1997
			AT 167215 T	15-06-1998
			CA 2155685 A1	10-02-1996
			CN 1126733 A	17-07-1996
			DE 69502893 D1	16-07-1998
			DE 69502893 T2	17-12-1998
			EP 0697436 A1	21-02-1996
			ES 2118480 T3	16-09-1998
			JP 8059916 A	05-03-1996
			US 5834562 A	10-11-1998

CORRECTED VERSION

(19) World Intellectual Property  
Organization  
International Bureau



(43) International Publication Date  
24 April 2003 (24.04.2003)

PCT

(10) International Publication Number  
WO 2003/033612 A1

(51) International Patent Classification<sup>7</sup>: C09J 123/10

(21) International Application Number:  
PCT/US2002/026297

(22) International Filing Date: 16 August 2002 (16.08.2002)

(25) Filing Language: English

(26) Publication Language: English

(30) Priority Data:  
09/982,641 18 October 2001 (18.10.2001) US

(71) Applicant: BOSTIK FINDLEY, INC. [US/US]; 11320  
Watertown Plank Road, Wauwatosa, WI 53226 (US).

(72) Inventors: WANG, Baoyu; W226 N2818 Foxwood Lane,  
Waukesha, WI 53186 (US). ZHANG, Chongyao; 4045  
North Prospect Avenue, Shorewood, WI 53211 (US).

(74) Agents: WOZNY, Thomas, M. et al.; Andrus, Scales,  
Starke & Sawall, LLP, Suite 1100, 100 East Winconsin Av-  
enue, Milwaukee, WI 53202 (US).

(81) Designated States (national): AE, AG, AL, AM, AT, AU,  
AZ, BA, BB, BG, BR, BY, BZ, CA, CH, CN, CO, CR, CU,

CZ, DE, DK, DM, DZ, EC, EE, ES, FI, GB, GD, GE, GH,  
GM, HR, HU, ID, IL, IN, IS, JP, KE, KG, KP, KR, KZ, LC,  
LK, LR, LS, LT, LU, LV, MA, MD, MG, MK, MN, MW,  
MX, MZ, NO, NZ, OM, PH, PL, PT, RO, RU, SD, SE, SG,  
SI, SK, SL, TJ, TM, TN, TR, TT, TZ, UA, UG, UZ, VN,  
YU, ZA, ZM, ZW.

(84) Designated States (regional): ARIPO patent (GH, GM,  
KE, LS, MW, MZ, SD, SL, SZ, TZ, UG, ZM, ZW),  
Eurasian patent (AM, AZ, BY, KG, KZ, MD, RU, TJ, TM),  
European patent (AT, BE, BG, CH, CY, CZ, DE, DK, EE,  
ES, FI, FR, GB, GR, IE, IT, LU, MC, NL, PT, SE, SK,  
TR), OAPI patent (BF, BJ, CF, CG, CI, CM, GA, GN, GQ,  
GW, ML, MR, NE, SN, TD, TG).

Published:  
— with international search report

(48) Date of publication of this corrected version:  
24 June 2004

(15) Information about Correction:  
see PCT Gazette No. 26/2004 of 24 June 2004, Section II

For two-letter codes and other abbreviations, refer to the "Guid-  
ance Notes on Codes and Abbreviations" appearing at the begin-  
ning of each regular issue of the PCT Gazette.

(54) Title: HOT MELT ADHESIVE COMPOSITION BASED ON A BLEND OF AMORPHOUS POLY-ALPHA-OLEFIN AND  
SYNDIOTACTIC POLYPROPYLENE

(57) Abstract: A hot melt adhesive composition based on a polymer blend of syndiotactic polypropylene (SPP) and atactic poly- $\alpha$ -olefin (APAO). The composition contains about 15%-80% by weight of the SPP/APAO blend, about 15%-65% by weight of a compatible tackifier, about 0%-35% by weight of a plasticizer, about 0%-3% by weight of a stabilizer, and optionally, about 0%-30% by weight of a wax. The adhesive composition may be used in a number of applications such as, for example, in disposable non-woven hygienic articles, paper converting, flexible packaging, wood working, carton and case sealing, labeling and other assembly applications.



WO 2003/033612 A1